

Three-phase On-grid String Inverter

SPI50K~60K-B Series



Product Features

High efficient

- 3 level topology, maximum efficiency 99%
- 4 MPPT design

Safe and reliable

- Outdoor IP65 design, no derating below 3000m altitude
- All industrial grade electronic device, ensure 25 years full life circle running.

Intelligent management

- Intelligent online upgrade function, easy upgrade and maintain
- Support RS485, Wifi, GPRS communication

Grid friendly

- Grid-connected current harmonics <3%, green adapts to grid
- Ultra wide grid voltage range

Function Diagram

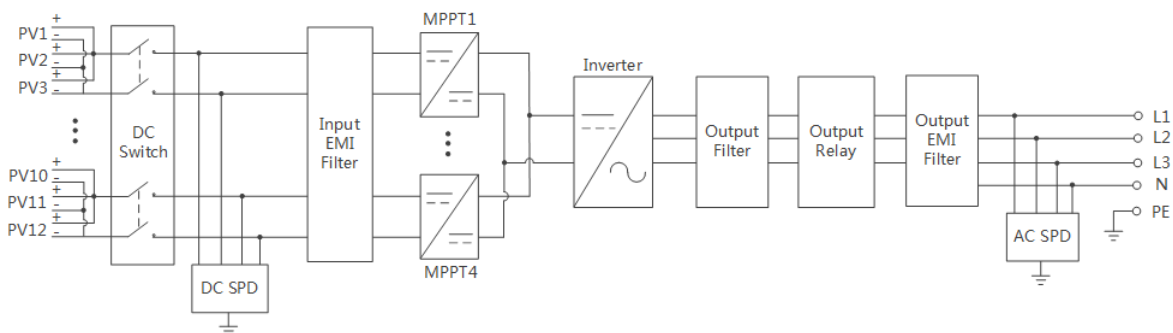

Technical Specification

Items	SPI50K-B	SPI60K-B
DC Input (PV)		
Max. PV input voltage	1000Vdc	
Rated input voltage	600Vdc	
Max. PV input current	4×30A	
No. of MPPTs	4	
No. of PV strings per MPPT	3/3/3/3	
MPPT voltage range	300~1000Vdc	
Starting voltage	250Vdc	
DC switch	Yes	
AC Output (On-grid)		
Rated AC output power	50kW	60kW
Max. output power	55kVA	66kVA
Rated AC output voltage	380/400/415Vac	
Rated output current	72.5A	86.6A
Max. output current	79.7A	95.3A
Rated grid frequency	50Hz/60Hz	
Grid frequency range	45~55Hz/55~65Hz	
Power factor	>0.99 (rated power)	
Adjustable power factor	0.8 (leading)~0.8 (lagging)	
THDi	<3% (rated power)	
Efficiency		
Max. efficiency	98.80%	99.00%
European efficiency	98.30%	98.45%
MPPT efficiency	99.90%	
Function and protection		
Anti-islanding	Yes	
DC(PV) reversed connection	Yes	
AC short circuit protection	Yes	
Temperature protection	Yes	
Surge protection	DC Type II & AC Type II	
General		
Dimensions (W×H×D)	600×860×294mm	
Weight	65kg	
IP grade	IP65	
Self-consumption at night	<1W	
Cooling type	Intelligent forced air cooling	
Altitude	4000m (>3000m derating)	
Operating temperature	-25°C~60°C	
Relative humidity	0~100%	
Display	LED+APP	
DC terminal	MC4 Terminal	
AC terminal	OT Terminal	
Installation method	Wall-mounted	
Communication	RS485, WIFI(optional)/GPRS (optional)	
Certification	IEC/EN62109-1, IEC/EN62109-2, EN61000, IEC60068, IEC61727, IEC62116, CEI0-16, CEI0-21, UTE C15-712-1, ENEDIS-NOI-RES_20E, VFR2019, DEWA2.0, IS16221, IS16169	

- Specifications are subject to change without prior notice.